



Designation: F680 – 17

Standard Test Methods for Nails¹

This standard is issued under the fixed designation F680; the number immediately following the designation indicates the year of original adoption or, in the case of revision, the year of last revision. A number in parentheses indicates the year of last reappraisal. A superscript epsilon (ϵ) indicates an editorial change since the last revision or reappraisal.

1. Scope*

1.1 These test methods cover procedures for the testing of nails. The test or tests selected, and the requirements for compliance, will be as specified in the applicable product standard. Performance tests for nail withdrawal and lateral load capability are not included as they are covered by Test Methods [D1761](#).

1.2 The tests described are as follows:

	Section
Dimensional tests	5
Tension test	6
Conventional bend test	7
Impact bend test	8
Rockwell hardness test	9
Coating weight test	10
Coating adherence test for zinc-coated nails	11

1.3 The values stated in inch-pound units are to be regarded as standard. The values given in parentheses are mathematical conversions to SI units that are provided for information only and are not considered standard.

1.4 *This standard does not purport to address all of the safety problems, if any, associated with its use. It is the responsibility of the user of this standard to establish appropriate safety and health practices and determine the applicability of regulatory limitations prior to use.*

1.5 *This international standard was developed in accordance with internationally recognized principles on standardization established in the Decision on Principles for the Development of International Standards, Guides and Recommendations issued by the World Trade Organization Technical Barriers to Trade (TBT) Committee.*

2. Referenced Documents

2.1 *ASTM Standards:*²

¹ These test methods are under the jurisdiction of ASTM Committee [F16](#) on Fasteners and are the direct responsibilities of Subcommittee [F16.05](#) on Driven and Other Fasteners.

Current edition approved June 1, 2017. Published June 2017. Originally approved in 1980. Last previous edition approved in 2012 as F680-80(2012). DOI: 10.1520/F0680-17.

² For referenced ASTM standards, visit the ASTM website, www.astm.org, or contact ASTM Customer Service at service@astm.org. For *Annual Book of ASTM Standards* volume information, refer to the standard's Document Summary page on the ASTM website.

- [A90/A90M Test Method for Weight \[Mass\] of Coating on Iron and Steel Articles with Zinc or Zinc-Alloy Coatings](#)
- [A370 Test Methods and Definitions for Mechanical Testing of Steel Products](#)
- [A428/A428M Test Method for Weight \[Mass\] of Coating on Aluminum-Coated Iron or Steel Articles](#)
- [D1761 Test Methods for Mechanical Fasteners in Wood](#)
- [E18 Test Methods for Rockwell Hardness of Metallic Materials](#)
- [F547 Terminology of Nails for Use with Wood and Wood-Base Materials](#)

3. Terminology

3.1 *Definitions*—For definitions of terms used in this test method, refer to Terminology [F547](#).

4. Significance and Use

4.1 When specified, the tests selected for application shall be performed to assure conformance with requirements stipulated in the product specification.

5. Dimensional Tests

5.1 Dimensions to be evaluated include, but shall not be limited to length, stock diameter, diameter or major dimensions of head, straightness, head concentricity to shank, and length of point. For mechanically deformed nails, angle, depth, and configuration of deformations shall be measured as specified. Other dimensional characteristics shall be measured when required. Any suitable measuring means may be applied.

6. Tension Test

6.1 Nails are not subject to tension testing. However, wire used to make the nails may be tested as required by prior agreement or to affect mill product control. The testing of wire is covered in the general section of Test Methods [A370](#) and Supplement IV, Round Wire Products.

7. Conventional Bend Test

7.1 This test is used as a means of testing the ductility of certain types of nails or of the wires used in the manufacture of nails. The angle of bend and the mandrel diameter will be specified in the product specification. The cold bending shall be performed by any hand or power device that will deform the sample closely about a mandrel of specified diameter through

*A Summary of Changes section appears at the end of this standard

the required angle without causing damage to the nail surface. The sample shall be considered to have failed if fracture occurs prior to attainment of the required minimum bend angle. Unless otherwise specified, the conventional bend test shall not be applied to annularly threaded nails or to the region of a nail exhibiting gripper marks.

8. Impact Bend Test

8.1 The impact test is primarily applicable to the testing of pallet nails to assess their suitability for that application. The testing device is shown in Fig. 1 and its operation is described in Annex A1. For any given diameter, the data from this test can be correlated with Rockwell hardness used to specify the mechanical properties of the nail. The impact bend test is intended as a convenient test that may be used in manufacturing and consumer quality monitoring of mechanical properties. However, in the case of dispute, the Rockwell hardness test, supplemented by the conventional bend test, will be considered the governing test.

9. Rockwell Hardness Test

9.1 This test is used to measure the hardness of heat-treated nails. Prepare flat surfaces by grinding or filing. Take care not

to alter the tempered hardness of the nail during preparation of the flats. The width of the prepared flat shall be sufficient to prevent edge bulge adjacent to each hardness impression. The thickness at the test section shall be sufficient to avoid a bulge or other visible markings on the surface opposite to the impression. Hardness can be determined using a shank having prepared parallel surfaces. Determine the hardness in accordance with Test Methods E18. Usually three readings are made on a nail and these readings are averaged for the final result.

9.2 An alternate method for determining Rockwell hardness is to cut the nail off about 1/2 in. (13 mm) from the head. Grind the top of the head to remove scale and obtain a flat surface. Grind the transversely cut end flat, using proper precautions not to alter the tempered hardness of the nail. Place the sample head down on the anvil of the hardness testing machine and determine the hardness on the transverse section.

10. Coating Weight Test

10.1 This test deals with zinc, aluminum, and copper-clad coatings only and does not deal with other metallic coatings such as cadmium.

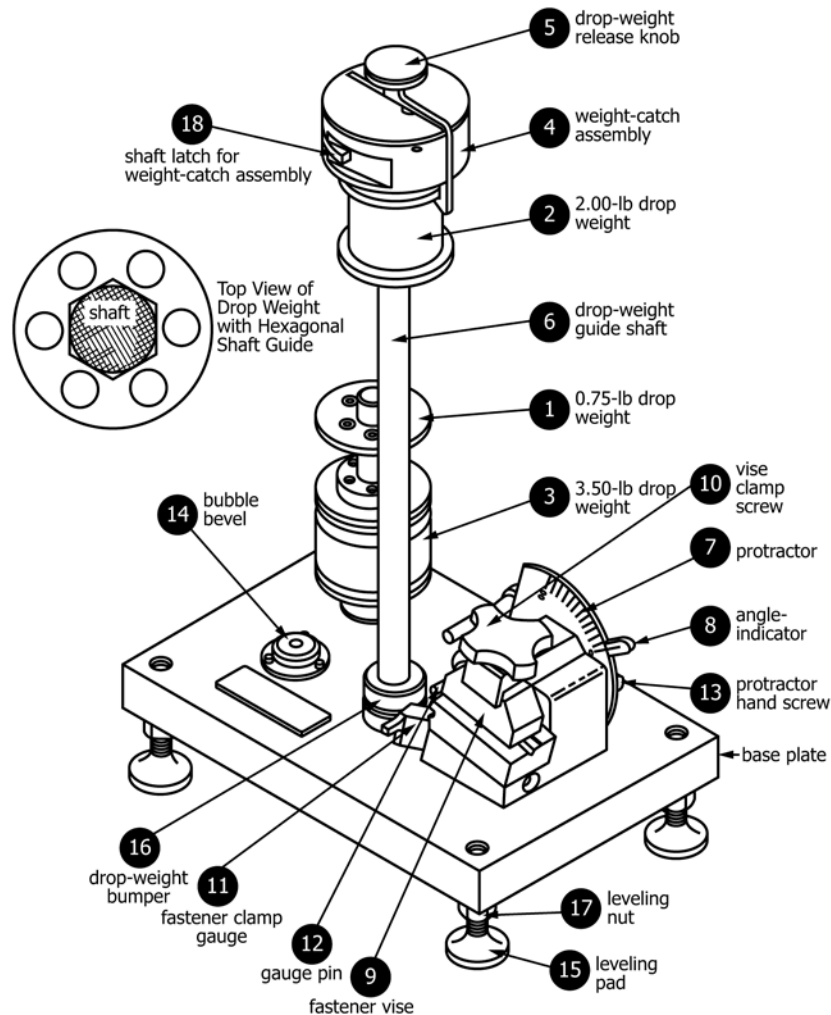

NOTE 1—This device is available from The National Wooden Pallet and Container Assn., 1625 Massachusetts Ave., Washington, DC 20036

FIG. 1 A Typical Impact Bend Tester for the Impact Bend Testing of Nails